

ISO SCALE 4 : 1

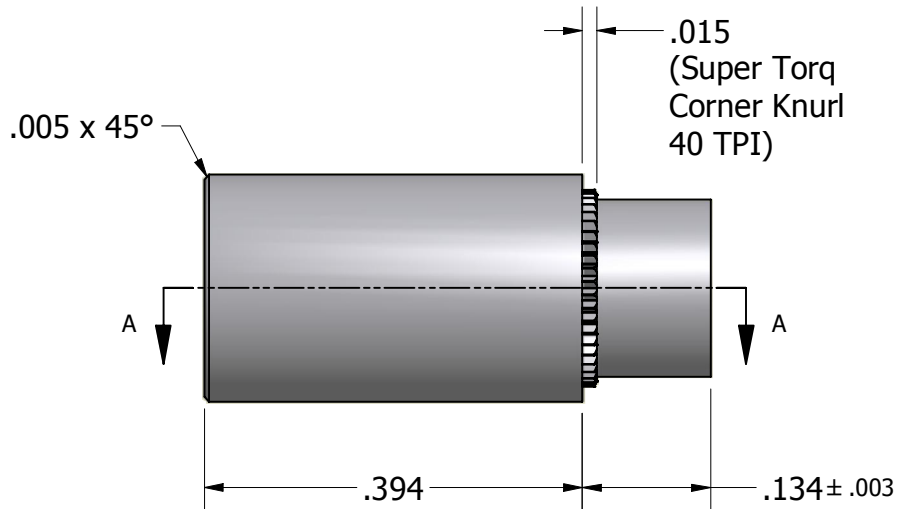

M3.0 X 0.5 - 6H THRU

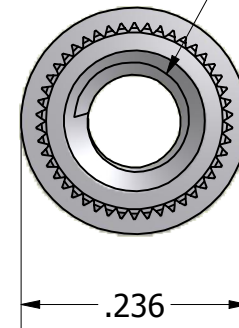

NOTES:
 (1) VACUUM ANNEAL BEFORE PLATING IF CRACKING

Tolerances Unless Otherwise Specified:

.xx Decimal: ± .01
.xxx Decimal: ± .004
Fraction: ± 1/64
Angle: ± 2°

LYN-TRON, INC.

Part Number:

ST5114SPC-10.0

Description:

6mm Round M3x.5 Swage Standoff

Drawn By:

Rick Z 9/27/2011

Gauge:

Material:

Steel

Scale:

5:1