

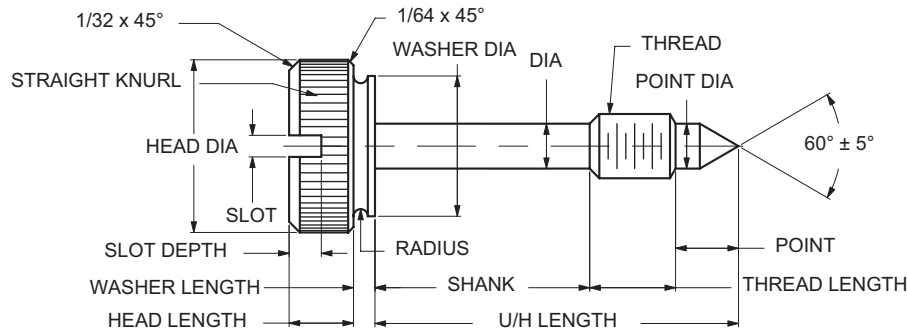

CAPTIVE PANEL SCREW TYPE 3



ORDERING CODE	XX	XXXX	XX
MATERIAL	BASIC PART	FINISH	
CODE	FINISH		
00	Plain — None		
01	Passivate ASTM A967-05		
61	Nickel QQ-N-290 CL 1, Type VI KC		

MATERIAL	CODE
BRASS	BR
STAINLESS STEEL	SS
STEEL	ST

Additional Finishes Available

BASIC PART NO	THREAD	HEAD DIA +0.010 -0.000	HEAD LGTH ±0.010	UNDER HEAD LGTH ±0.015	THD LGTH ±0.010	SHANK DIA ±0.005	SHANK LGTH ±0.010	POINT DIA +0.000 -0.010	POINT LGTH ±0.015	WASH DIA ±0.010	WASH LGTH ±0.010	SLOT WIDTH +0.005 -0.000	SLOT DEPTH +0.010 -0.000	KNURL TPI
3772	1/4-28	5/8	3/16	1-3/16	3/8	.175	9/16	.175	1/4	1/2	1/16	5/64	3/32	30
3773	1/4-28	5/8	3/16	1-1/4	3/8	.175	5/8	.175	1/4	1/2	1/16	5/64	3/32	30
3774	1/4-28	5/8	3/16	1-5/16	3/8	.175	11/16	.175	1/4	1/2	1/16	5/64	3/32	30
3775	1/4-28	5/8	3/16	1-3/8	3/8	.175	3/4	.175	1/4	1/2	1/16	5/64	3/32	30
3776	1/4-28	5/8	3/16	1-7/16	3/8	.175	13/16	.175	1/4	1/2	1/16	5/64	3/32	30
3777	1/4-28	5/8	3/16	1-1/2	3/8	.175	7/8	.175	1/4	1/2	1/16	5/64	3/32	30
3778	1/4-28	5/8	3/16	1-9/16	3/8	.175	15/16	.175	1/4	1/2	1/16	5/64	3/32	30
3779	1/4-28	5/8	3/16	1-5/8	3/8	.175	1"	.175	1/4	1/2	1/16	5/64	3/32	30
3780	1/4-28	5/8	3/16	1-11/16	3/8	.175	1-1/16	.175	1/4	1/2	1/16	5/64	3/32	30
3781	1/4-28	5/8	3/16	1-3/4	3/8	.175	1-1/8	.175	1/4	1/2	1/16	5/64	3/32	30
3782	1/4-28	3/4	1/4	3/4	3/8	.175	1/8	.175	1/4	1/2	1/8	3/32	1/8	30
3783	1/4-28	3/4	1/4	13/16	3/8	.175	3/16	.175	1/4	1/2	1/8	3/32	1/8	30
3784	1/4-28	3/4	1/4	7/8	3/8	.175	1/4	.175	1/4	1/2	1/8	3/32	1/8	30
3785	1/4-28	3/4	1/4	15/16	3/8	.175	5/16	.175	1/4	1/2	1/8	3/32	1/8	30
3786	1/4-28	3/4	1/4	1"	3/8	.175	3/8	.175	1/4	1/2	1/8	3/32	1/8	30
3787	1/4-28	3/4	1/4	1-1/16	3/8	.175	7/16	.175	1/4	1/2	1/8	3/32	1/8	30
3788	1/4-28	3/4	1/4	1-1/8	3/8	.175	1/2	.175	1/4	1/2	1/8	3/32	1/8	30
3789	1/4-28	3/4	1/4	1-3/16	3/8	.175	9/16	.175	1/4	1/2	1/8	3/32	1/8	30
3790	1/4-28	3/4	1/4	1-1/4	3/8	.175	5/8	.175	1/4	1/2	1/8	3/32	1/8	30
3791	1/4-28	3/4	1/4	1-5/16	3/8	.175	11/16	.175	1/4	1/2	1/8	3/32	1/8	30
3792	1/4-28	3/4	1/4	1-3/8	3/8	.175	3/4	.175	1/4	1/2	1/8	3/32	1/8	30
3793	1/4-28	3/4	1/4	1-7/16	3/8	.175	13/16	.175	1/4	1/2	1/8	3/32	1/8	30
3794	1/4-28	3/4	1/4	1-1/2	3/8	.175	7/8	.175	1/4	1/2	1/8	3/32	1/8	30
3795	1/4-28	3/4	1/4	1-9/16	3/8	.175	15/16	.175	1/4	1/2	1/8	3/32	1/8	30
3796	1/4-28	3/4	1/4	1-5/8	3/8	.175	1"	.175	1/4	1/2	1/8	3/32	1/8	30
3797	1/4-28	3/4	1/4	1-11/16	3/8	.175	1-1/16	.175	1/4	1/2	1/8	3/32	1/8	30
3798	1/4-28	3/4	1/4	1-3/4	3/8	.175	1-1/8	.175	1/4	1/2	1/8	3/32	1/8	30

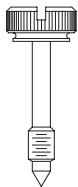

E25