

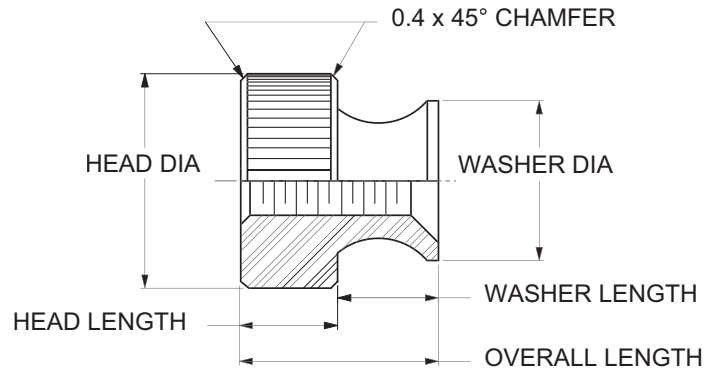

METRIC ROUND THUMB NUTS



CODE	FINISH
00	Plain — None
01	Passivate ASTM A967-05
61	Nickel QQ-N-290 CL 1, Type VI KC

MATERIAL	CODE
BRASS	BR
STAINLESS STEEL	SS
STEEL	ST

BASIC PART NUMBER	THREAD	HEAD DIA +0.5 -0.0	HEAD LENGTH ±0.5	OVERALL LENGTH (REF.)	WASHER LENGTH ±0.5	WASHER DIA ±0.5
5560	M2.5X0.45	6	3	6	3	5
5561	M3X0.5	8	3	6	3	6
5562	M3.5X0.6	10	3	7	4	9
5563	M4X0.7	10	3	7	4	9
5564	M5X0.8	13	4	9	5	11
5565	M6X1	13	4	9	5	12
5566	M8X1.25	19	6	12	6	16

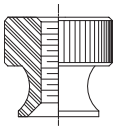

D25